

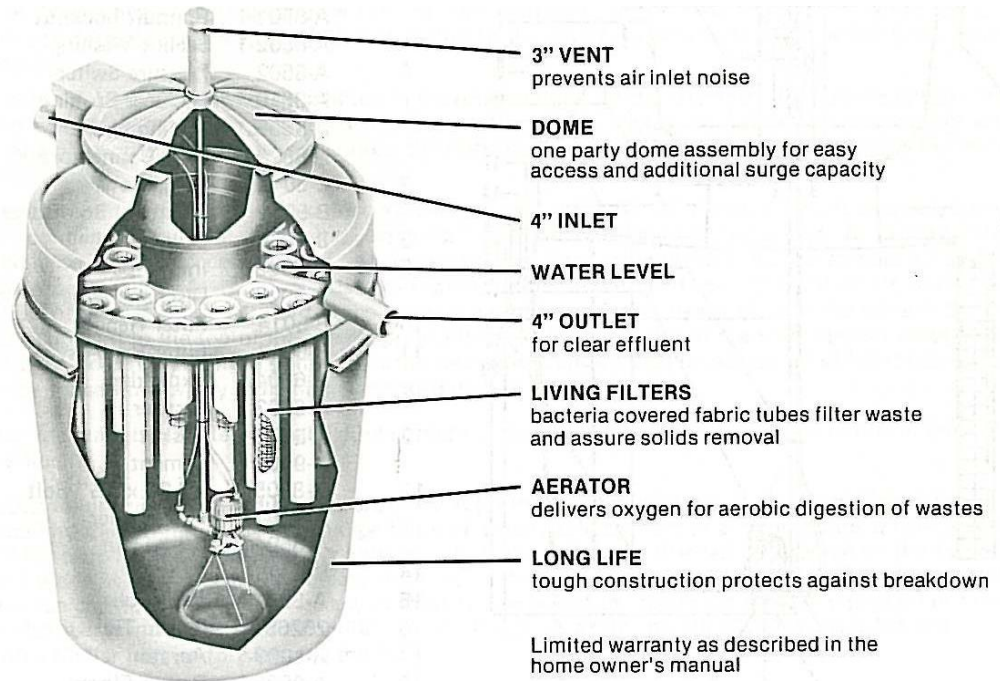

Education on Common Household Sewage Treatment Systems Found In Allen County, OH

The Allen County Public Health Environmental Health Division would like to provide you with diagrams of some common, discontinued systems. This information should assist you in better understanding the way your household sewage is processed. Please refer to your Operation and Maintenance Manual for detailed instructions for how to care for your system. If you have any questions, please contact the Health Department at 419-228-4457.

Multi Flo Home Wastewater Treatment Plant



PROCESS DESCRIPTION

The Multi-Flo Model FTB-0.5 provides aerobic treatment as a filtered effluent treatment process utilizing a submerged mechanical aerator. Wastewater flows into the center of the plant and drops into the aeration chamber. The aerator at the bottom of the chamber draws air into the plant through a vertical pipe due to the suction created by a rotating impeller; the air is dispersed radially near the bottom of the chamber. Air travels upward and outward and some of the oxygen present is transferred to the process fluid. The oxygen transfer produces an environment conducive to the growth of aerobic bacteria, which break down organic material by metabolism.

The flow of air in the chamber induces a pattern of circulation in the process fluid. In the chamber, fluid travels upward and a portion is diverted out and away from the center just below the filter support plate. Hence, fluid circulates horizontally across the hanging filter tubes. Along the outside walls of the aeration chamber, fluid travels downward and thence along the bottom of the chamber back to the aerator.

The filter tubes that hang suspended in the process fluid are cylindrical, closed at the bottom; they are made of a polyester felted material. Each tube contains a vinyl-coated metallic "expander" that resists hydraulic pressure from the process fluid, which would cause the tube to collapse. As the process matures, the surface of each filter accumulates a mass of aerobic bacteria and, in this sense, the filter tubes become "living" filters. The extent of bacterial build-up is limited and regulated by the constant washing action of the horizontal flow of process fluid. All fluid which leaves the aeration chamber passes through the walls of the filters and by hydraulic pressure travels upward to the top of the filter support plate. At the perimeter of the filter support plate, there is a circular effluent weir and collection trough. Before spilling over the weir, the relatively slow movement of effluent over the support plate affords an opportunity for settling of any remaining suspended matter.

Effluent is discharged from the plant by simple hydraulic displacement; a specific volume of influent flow results in the discharge of an equivalent volume of effluent.

Positive indicators of process failure, visible or audible, are provided. A pressure switch mounted in the air suction pipe monitors the suction created by the aerator. If the intake pipe fills with water, as in the case of aerator failure, a fault indicator lamp on the control panel lights up and/or a small electric horn sounds; the horn may be silenced by a switch on the control panel but the lamp stays on until the fault is corrected. A mercury float switch monitors the level of the process fluid in the aeration chamber. Because the aeration chamber level would rise and eventually overflow if the filters were partially plugged or failed entirely, fluid level in the aeration chamber is indicative of the condition of the filters. If a safe operating level is exceeded, the fault horn /or lamp are activated with a similar proviso for silencing the horn.

Jet Plant

The Jet plant is constructed of rugged permanent concrete. Its patented design incorporates three separate compartments, each performing a specific function in the total purification process.

1 The Primary Treatment compartment receives the household sewage and holds it long enough to allow solid matter to settle to the sludge layer at the tank's bottom. Organic solids are here broken down physically and bio-chemically by anaerobic bacteria — those bacteria that live and work without oxygen. Grit and other untreatable materials are settled out and held back. The partially broken down, finely divided material that is passed on to the aeration compartment is much easier to treat than raw sewage. This, of course, is the reason for Jet's primary compartment. It's one of the steps that make it possible for Jet plants to reduce incoming sewage to a clear effluent within the short period of 24 hours.

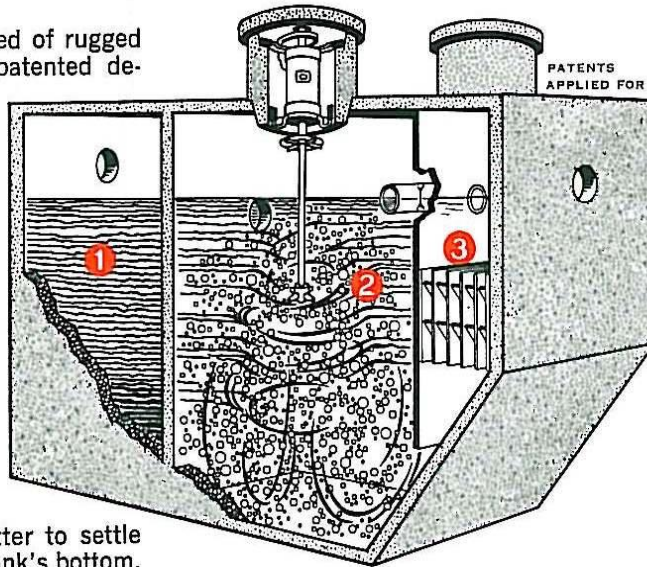

2 In the Aeration chamber the finely divided, pre-treated material from the primary compartment is mixed with activated sludge and aerated. The patented Jet aerator injects large quantities of fresh air into this compartment to provide oxygen for the aerobic digestion process, and it thoroughly mixes the compartment's entire contents.

The aerator is mounted in a concrete housing that rises to ground level to give it access to fresh outside air. In injecting air into the liquid, the aerator

breaks up the air into tiny bubbles so more air comes in contact with the liquid, thus hastening the aerobic digestion process. Aerobic bacteria, which are bacteria that live and work in the presence of oxygen, then use the oxygen in solution to completely break down the sewage and convert it to odorless liquids and gases.

The Aeration compartment has a 50% greater capacity than is required in the National Academy of Sciences—National Research Council Criteria. This extra capacity gives a Jet plant a more-than-adequate safety factor to handle shock loads from weekend guests, multiple baths, automatic laundries, and dish-washers.

3 The final phase of the operation takes place in the settling/clarifying compartment. In this compartment a tube settler eliminates currents and encourages the settling of any remaining settleable material which is returned, via the tank's sloping end wall, to the aeration compartment for further treatment. A non-mechanical surface skimmer, operated by hydraulics, skims any floating material from the surface of the settling compartment and returns it to the aeration compartment. The remaining odorless, clarified liquid flows into the final discharge line through the baffled outlet.

*"Evolution of the Suburban STP," Stanley E. Kappe, Sanitary Engineer, from *Water and Sewage Works*, Reference Number, 1963.

Maintaining The Filter

Because household sewage treatment installations must operate economically and generally unattended, Jet designed its filter to cut maintenance and maintenance cost to the bone. The filter does not lose efficiency because of the accumulation or entrapment of solids in the filtering medium. Filter treatment decreases only when biological growth in the medium seals off the voids in the medium that allow fluid passage. Consequently, routine backwashing of the medium every six months is recommended. This is the only maintenance normally required. If the filter is maintained as recom-

mended, this job takes only minutes and requires no excavation or inconvenience to the homeowner. It is performed through the concrete access riser on top of the tank by qualified service personnel of the licensed Jet distributor, usually during a routine inspection of the home plant. Since the backwash from the filter is pumped into the treatment plant's aeration chamber, no tank trucks or other heavy equipment are needed. An inspection/service policy is available from Jet distributors to cover filter backwashing.

Specifications

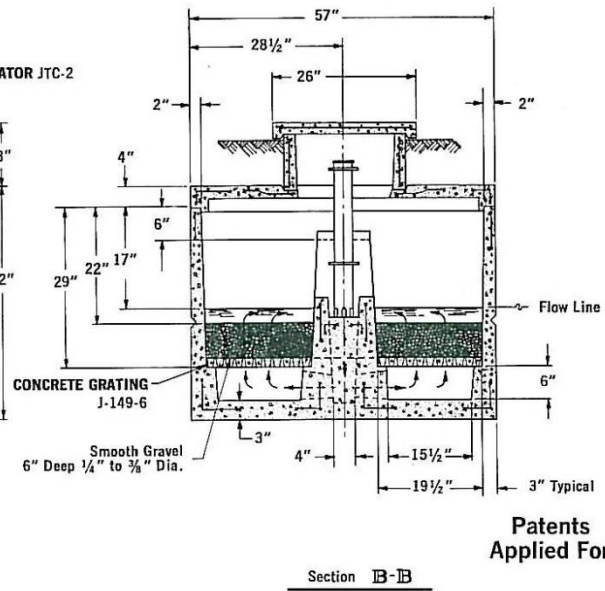
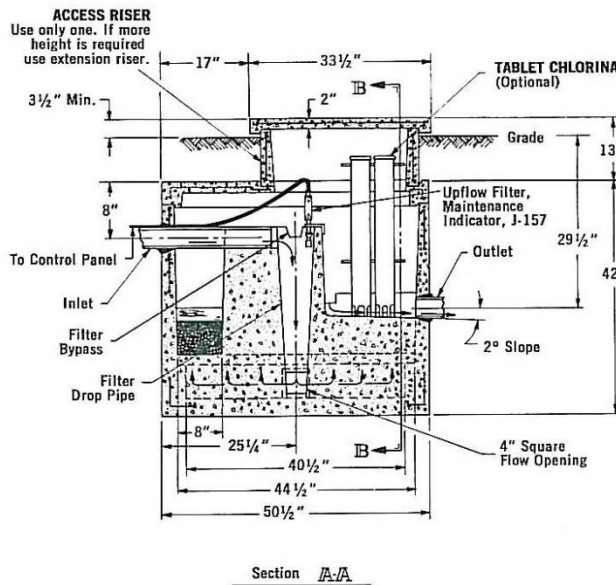

Patents Applied For

GENERAL

Furnish and install (1) Jet Upflow Filter, as manufactured under license and specifications of Jet Aeration Company, Cleveland, Ohio, U.S.A., to provide tertiary treatment for the effluent from the Jet Home Sewage Treatment Plant.

TANK

The filter tank shall be manufactured of precast reinforced concrete and shall be equipped with concrete cover, necessary riser(s), concrete grating to support filter medium, as shown on Drawing #J-149. Tank shall have a 110-gallon capacity and 12 square feet of filter area. It shall be equipped with removable access cover at grade. An internal outlet channel, suitable for use with the optional Jet Tablet Chlorinator, shall be provided.

FILTERING MEDIUM

The filtering medium shall be 1/4" to 3/8" diameter smooth pea gravel, or approved alternate, to a depth of 6".

INSTALLATION

The filter shall be mounted inline after the clarifying compartment of the Jet Home Plant.

OPTIONAL CHLORINATOR

The filter shall be equipped with a Jet Tablet Chlorinator, as specified in the brochure "Jet Home Effluent Chlorination."

OPTIONAL MAINTENANCE INDICATOR*

The filter shall be equipped with a maintenance indicator which activates a warning light in the home to notify the owner that the filter needs backwashing.

OPTIONAL GRATING

The filter tank shall be covered with hinged, padlocked steel bar grating in lieu of the standard concrete cover.

*This option must be included on all installations requiring N.S.F. approval.



Oldham Sewage Treatment System

THE TREATMENT PROCESS IS ACCOMPLISHED IN 3 STEPS

The Oldham Sewage Treatment System utilizes the extended aeration process that treats sewage by stabilization of organic matter. This is achieved by thoroughly mixing fresh and treated sewage in an oxygen saturated environment combined with continuously controlled sludge return. Extended aeration of the recirculating solids produces a clear odorless effluent.

This system complies with the latest Ohio Department of Health guidelines.

- 1** The first compartment, 400 gallons capacity, receives the raw sewage from the house. All foreign matter and heavier solids settle in this compartment. The solids which will decompose in water (comprising more than 99% of the solids) together with the liquid waste, then pass through a vitrified elbow into the second compartment.
- 2** In this compartment, air, which is supplied by a positive displacement type pump located in a concrete riser on the top of the tank, is discharged into the contents of the compartment near the inlet wall and near the bottom of the tank. The discharge of air at this point causes the liquid in the compartment to circulate or roll with sufficient force that all of the solids in the sewage are maintained in suspension in the liquid. Oxygen in the solution creates an environment favorable to the growth of aerobic bacteria. These microscopic organisms digest the solids in the sewage within a period of 24 hours. The capacity of this compartment is 600 gallons, which is the daily treatment capacity of the system. The average sewage flow from an individual residence is 400 gallons per day. **Backwash water containing salt from water softeners should by pass this system.**
- 3** The third compartment is the clarifier. When the contents of the aeration compartment enter the clarifier, the treated solids, no longer subjected to the rapid circulation of the aeration compartment, settle to the bottom of the clarifier and return to the aeration compartment by gravity through a slot, where they are further digested. The lighter solids, which will float, are returned to the aeration compartment by means of a skimming device located at the surface of the liquid. Clear liquid is discharged from the clarifier from a point 2" below the surface of the liquid, through a vitrified elbow, and then carried to the point of discharge through the effluent pipe. The clear liquid, called effluent, discharging from the tank, contains sufficient dissolved oxygen to guarantee a stable effluent, suitable for discharge directly into field tile, storm sewers, or suitable streams, under the jurisdiction of the local health department.

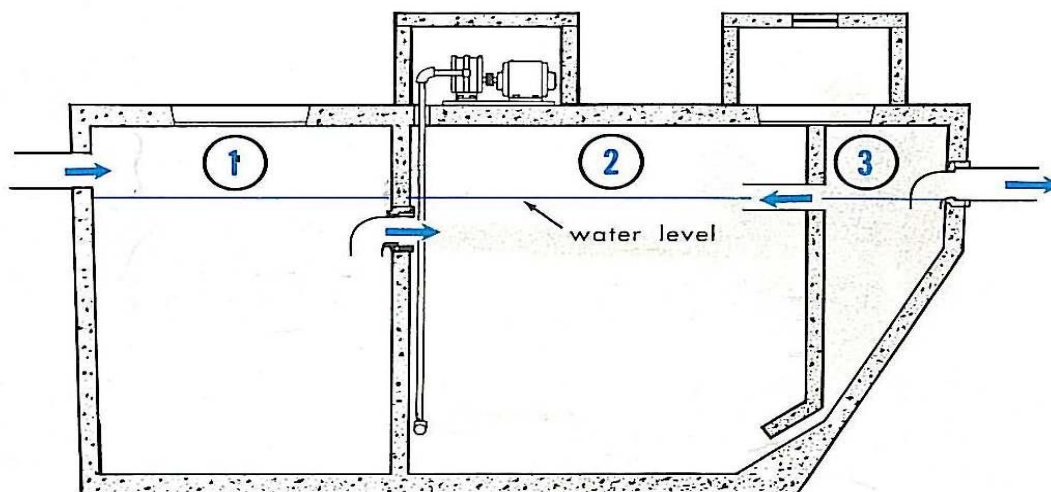

Typical Oldham Filter (prior to 1980)

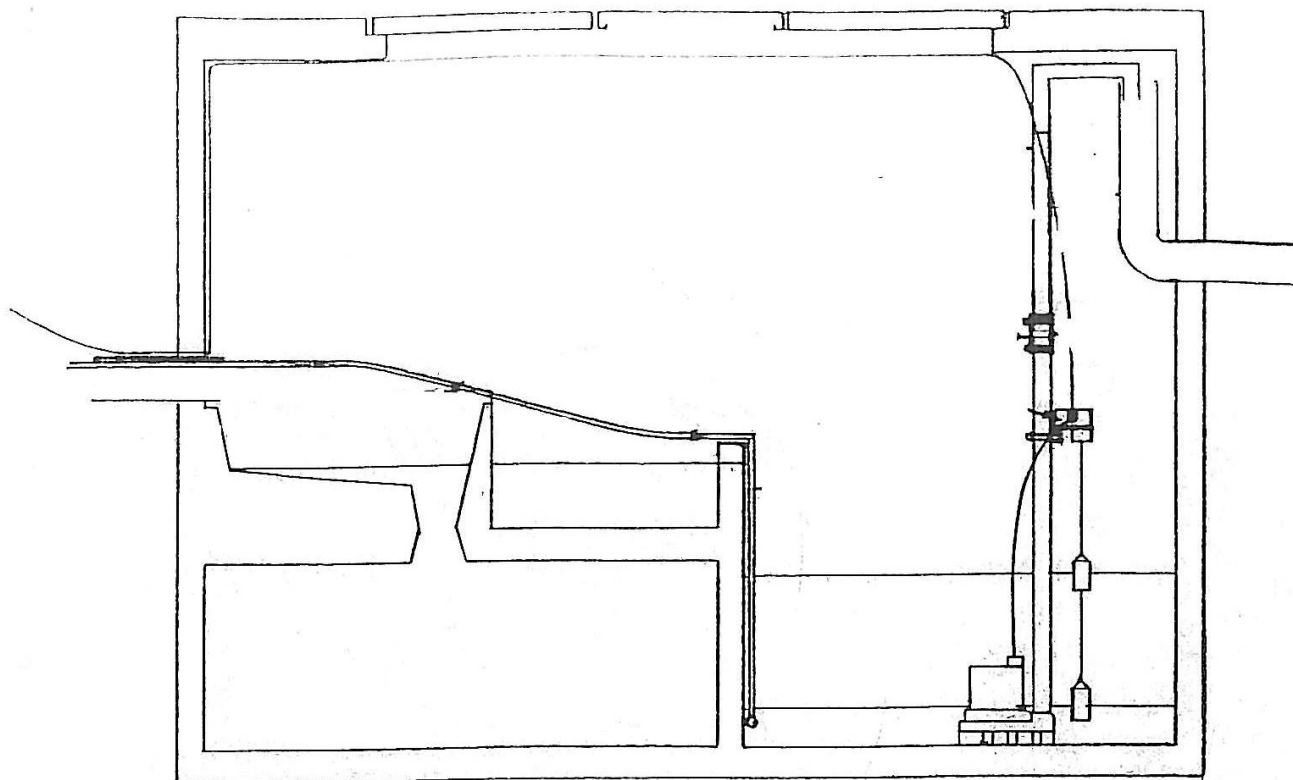

Typical Oldham Filter (1980-present)

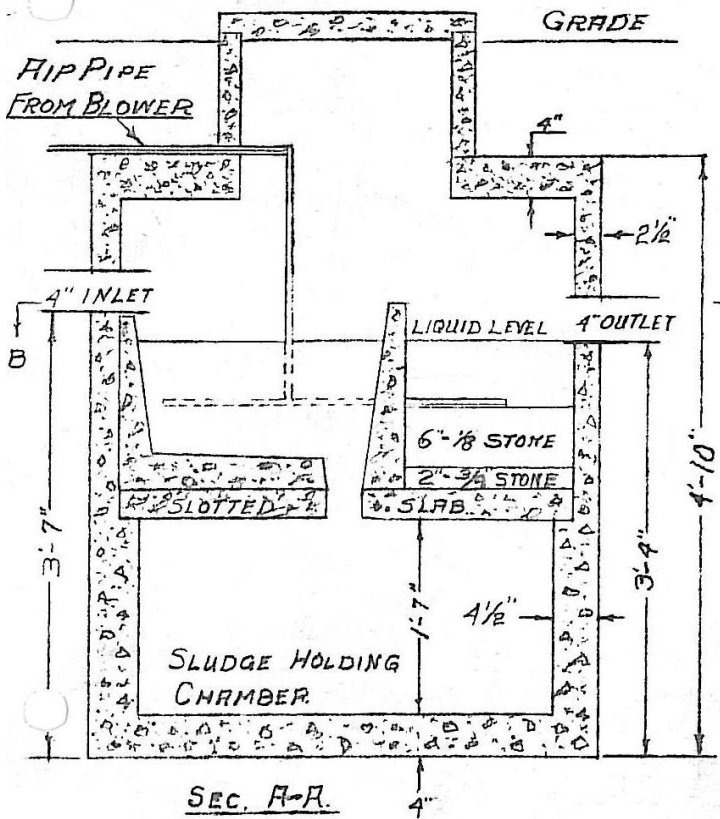
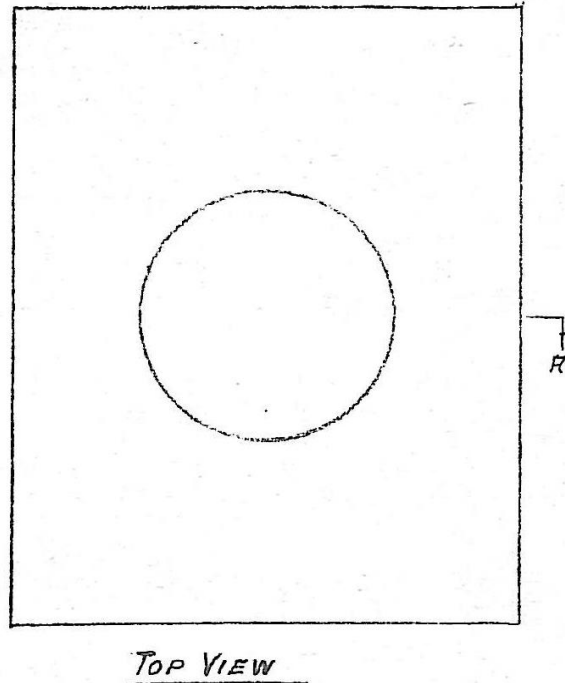
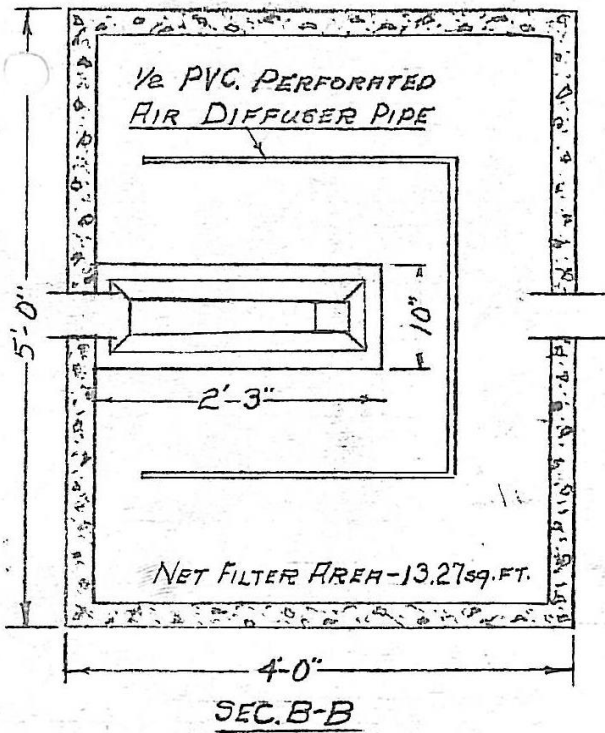

FILTER AREA 13.25 Sq. Ft.
 SLUDGE HOLDING 163 GAL.
 FILTERED EFFLUENT RES. 50 GAL.

AERATED UPFLOW FILTER FOR RESIDENTIAL SEWAGE TREATMENT SYSTEM
 MFG. BY ROBERT R. OLDHAM, INC.
 SIDNEY, OHIO, 45365

One and Two Compartment Septic Tanks

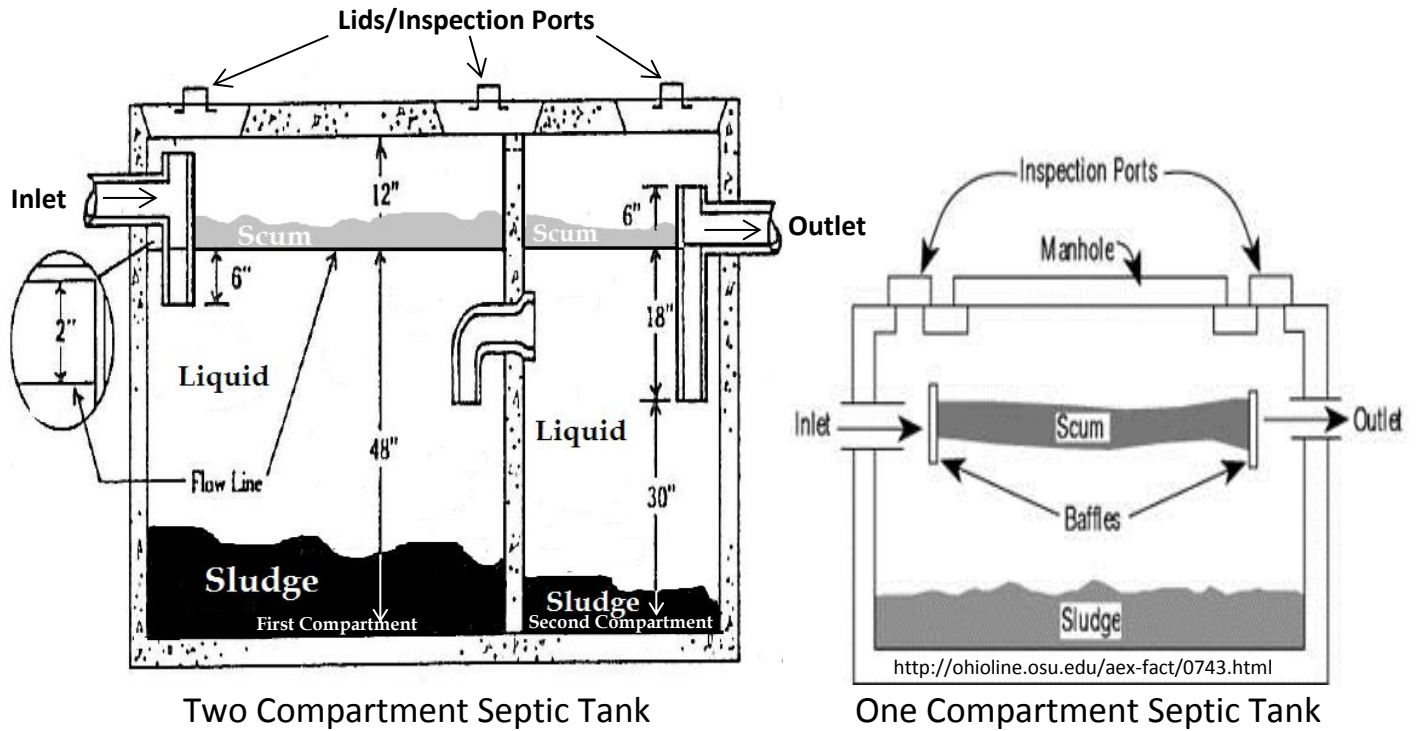

Septic tanks are primary treatment devices for wastewater. Wastewater leaves the building and enters the first or only compartment of the septic tank. Septic tanks are designed to retain sewage flows for a 24-hour period or longer. During this retention period, 60-70% of suspended solids either settle to the bottom as sludge, or float to the top as scum. Anaerobic bacteria will work in the septic tank to digest and reduce the volume of the solid matter. For two compartment tanks, after the first compartment, wastewater enters the second compartment to again reduce suspended solids flowing into the secondary treatment system. The liquid wastewater then exits the septic tank and continues on to the secondary treatment system. Inlet and outlet baffles must be in place for the tank to function as intended. Septic tanks installed since 2007 are equipped with an effluent filter in the outlet baffle to catch more solid materials before it enters the secondary treatment system. Septic tank effluent filters need to be cleaned every year. Properly functioning septic tanks will prolong the life of the secondary treatment system. The best way to keep a system functioning properly is to have it cleaned at the recommended interval for the specific system.

Subsurface Sand Filter

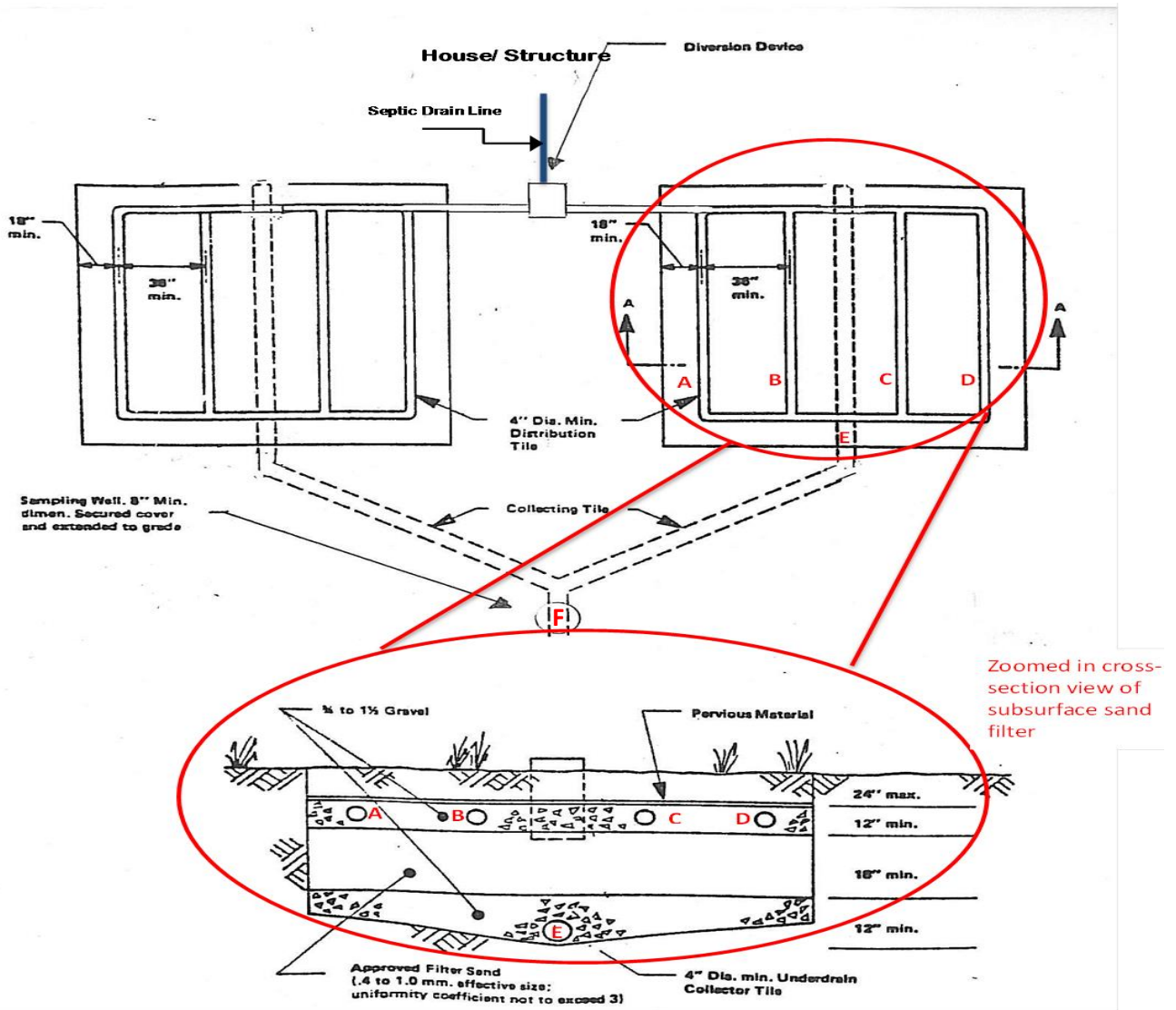

Following primary treatment in a septic tank, treatment continues in the secondary system. One type of secondary treatment system is a subsurface sandfilter. In a sandfilter the septic tank effluent is dispersed through tiles (A-D) into a gravel layer of stone. The effluent will then slowly flow downward through two and a half feet of sand and gravel to a collecting tile (E) at the bottom. As the septic tank effluent filters down through this filter, solids will be physically removed and nutrients will be biologically removed. As nutrient rich effluent passes through the layers of the sandfilter, the concentration of nutrients in the effluent is significantly reduced. For the filter to work effectively, the under drain must be tiled into a working outlet so that the filter does not retain liquid. Subsurface sandfilters installed after 1980 were installed with alternating devices in the diversion boxes to allow for annual resting of beds. Sanitarians observe grab samples from the sampling well (F) during inspections to ensure the system does not create a public health nuisance.

Dosing Chamber/Lift Station

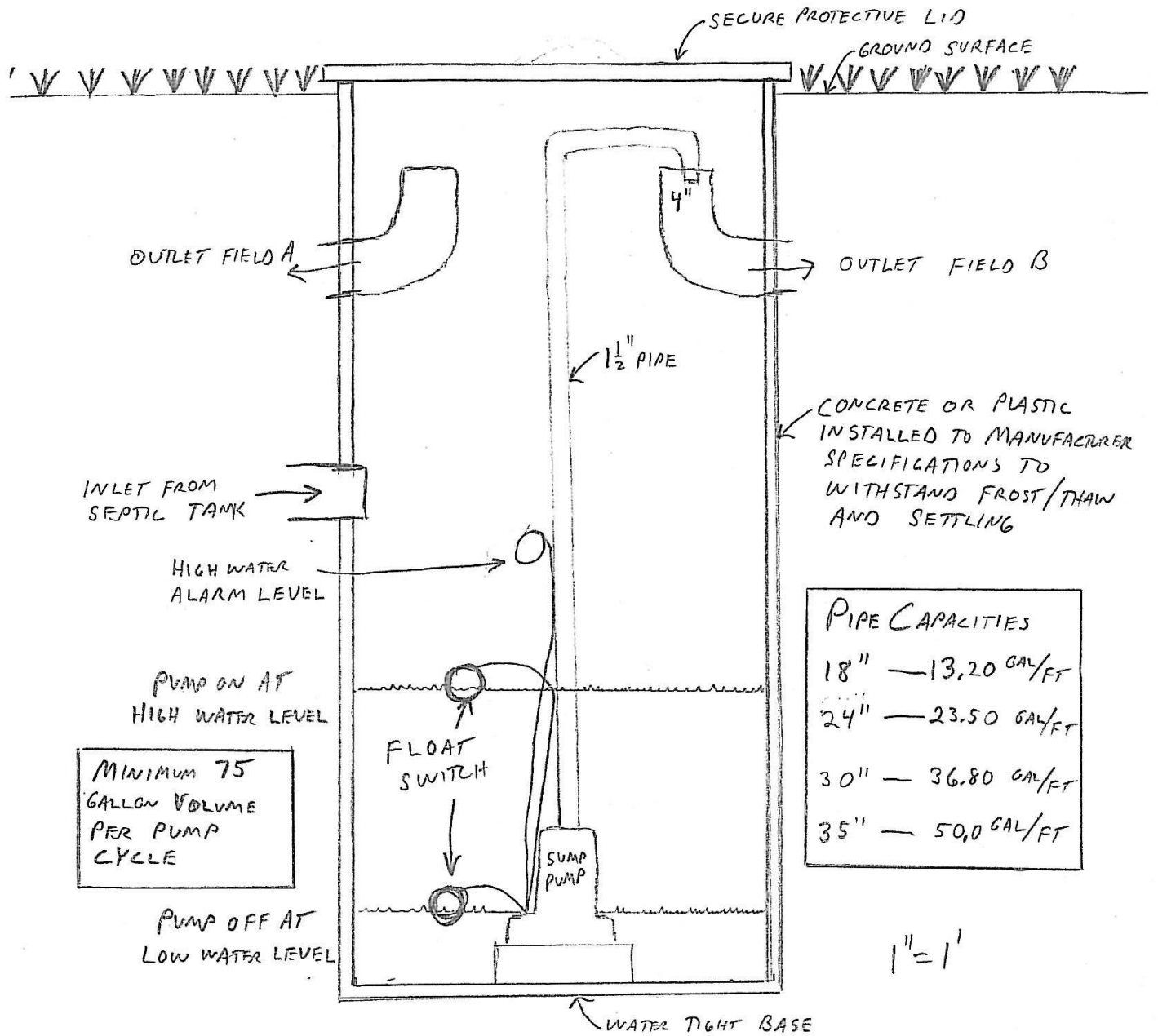

DIVERSION BOX / LIFT STATION TYPICAL DESIGN

Leaching Tile Field

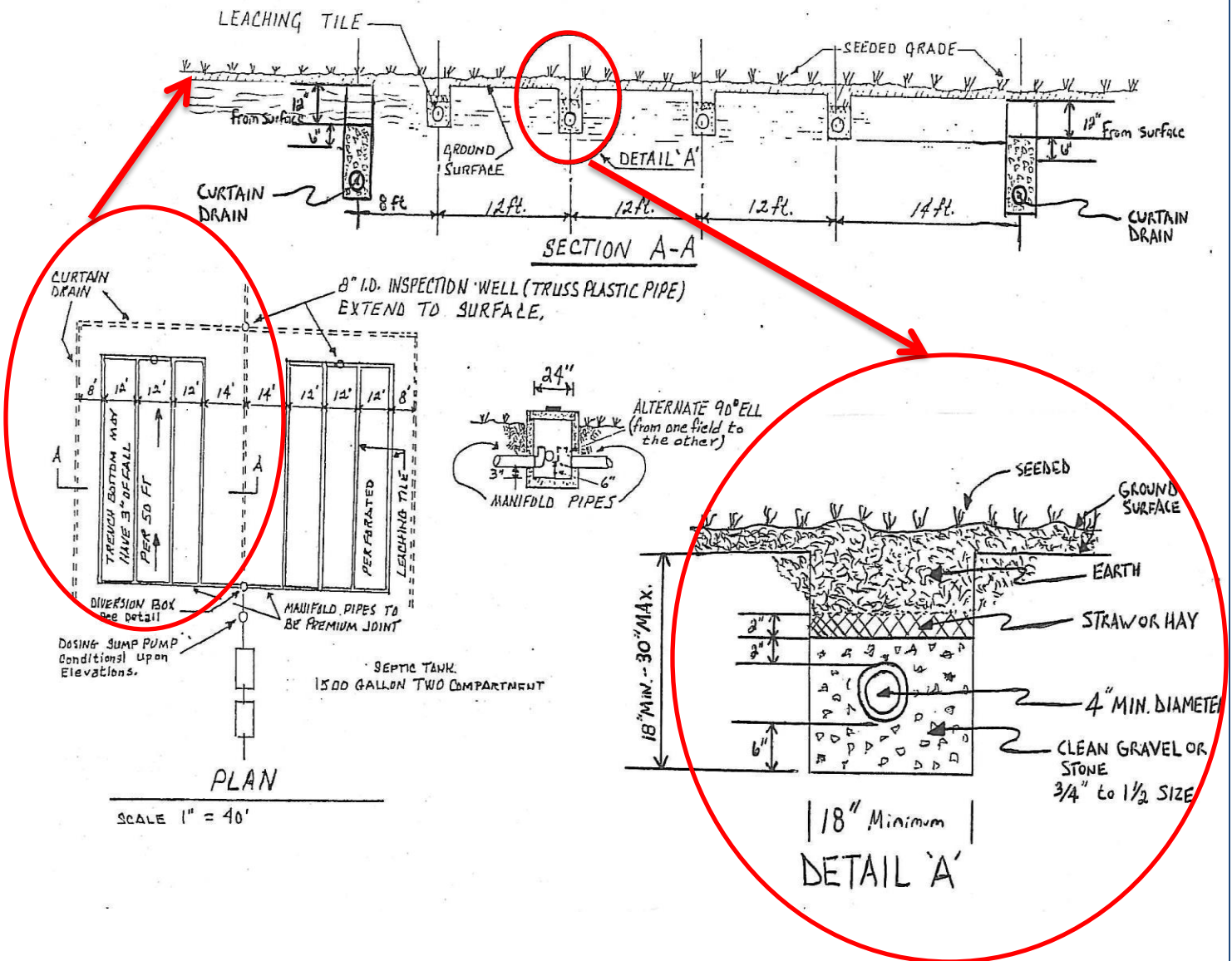

Following primary treatment in a septic tank, sewage treatment takes place in the secondary system. One type of secondary treatment system is a leaching tile field. In a leaching tile field the septic tank effluent is dispersed through leaching trenches. These trenches allow for the sewage effluent from primary treatment to percolate into the soil for natural filtration. Leaching tile field have no off-lot discharge of treated sewage and are a true disposal system. From the mid 1970's until 2010 leaching tile fields were installed with alternating devices in the diversion box to allow for restriction of flow to one side or the other. Alternating beds allows for systems to dry out and go through frost and thaw cycles to restore the soil interface to better accept sewage effluent. Surrounding a leaching tile field, curtain drains were likely installed to lower the ground water table in the leaching tile field area to better accept more sewage effluent. Sanitarians observe septic tank risers, diversion boxes and liquid levels in inspection ports. There should be no surfacing of sewage effluent on the surface of the ground. The water in the curtain drain 8" inspection well is to be free flowing and have no septic odor.